

TRILITE[®]

RMS BOARD

Reinforce Magnesium Silicate

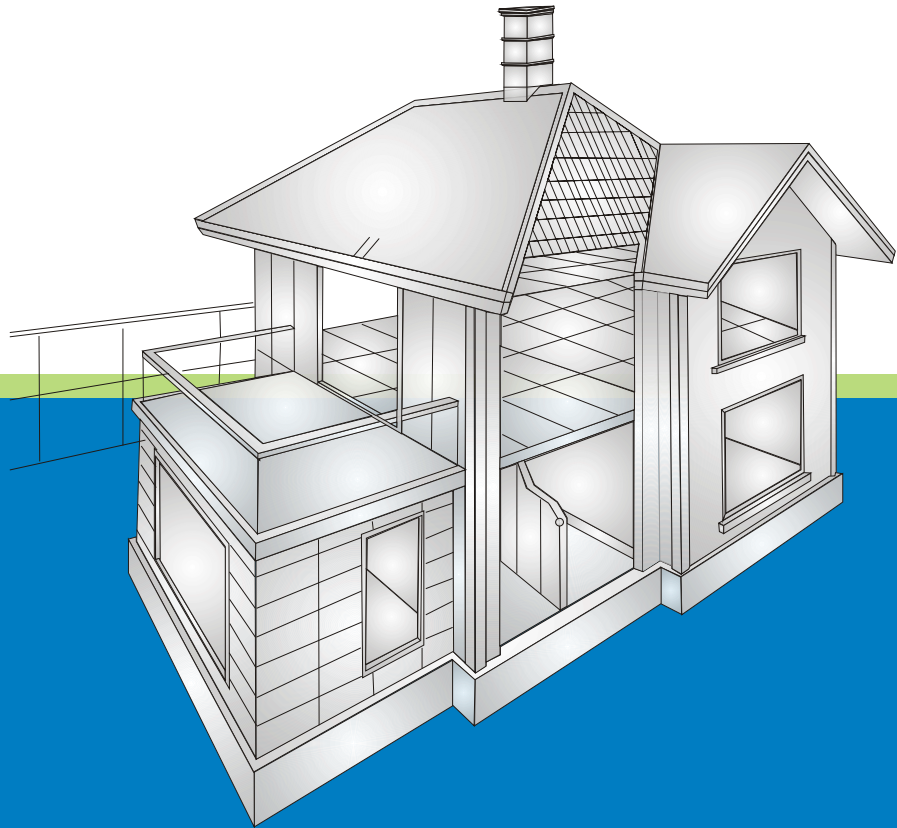

DARE TO BE DIFFERENT - Quality Matters
External & Internal Applications

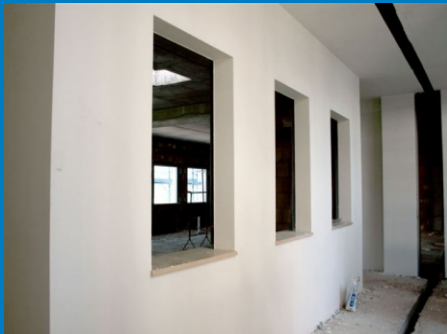

GO GREEN ENVIRONMENT



100%
ASBESTOS
FREE

Global warming is a fact, our actions now will help preserve our environment for a better tomorrow.

TRILITE RMS boards are produced with minimum emission of CO² which is high on the list of "greenhouse" effect, that contributes to global warming phenomenon. RMS board production is energy friendly curing is achieved with minimum energy consumption. It's "green" and an "eco-friendly" board.

It does not contain toxic components such as formaldehyde, asbestos, organic solvents, heavy metals or oil, totally SAFE and Environmental Friendly.

The Right Stuff

TRILITE RMS board is produced from a matrix of inorganic substances i.e: Natural silicates, MgO, CaCO₃, MgSO₄, Perlite and other inorganic fillers. The unique formula is distinct and separates our board from the rest in terms of durability, technical performance, fire resistance and stability. A chloride free formula ensures no halogenide effect and will not corrode steel structures.



Bevelled Edge

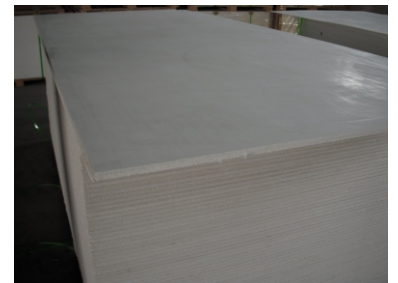

Square Edge



Tapered Edge



CE Conformity Number : 143SH200005029 as per requirements of FPC of BS EN 12467:2012, attestation of conformity System 4 and Construction Products Regulation Number 305/2011.



TRILITE RMS boards used as cladding in Europe

Approval Certificates issued by :



Fire Resistance

Combustibility

(In accordance to BS 476 Part 4)
(In accordance to DIN EN ISO1182)

Non-combustible

Gross Heat of Combustion

(In accordance to DIN EN ISO1716))

0.127 MJ/kg

Surface spread of flame

(In accordance to BS 476 Part 7)

Class 1

Building regulation classification

(In accordance to DIN EN ISO 13501-1)

A1 or A1_{fl} Euroclass

Surface Burning Characteristics

(In accordance to ASTM E-84)

Class A

Flame Spread = 0

Smoke Developed = 0

12mm - Single Board Only

(In accordance to BS 476 Part 22)

180 minutes fire rating

12mm - Timber & Steel Partition

(In accordance to BS 476 Part 22)

132 minutes fire rating- Steel

123 minutes fire rating- Timber

9mm - Steel Partition

(In accordance to BS 476 Part 22)

71 minutes fire rating



Area of Application



- Eaves lining
- Fascias
- Soffits
- Ceilings
- Canopies
- Porch lining



TRILITE RMS is suitable for a wide range of applications and is always ahead in the building board technology meeting the stringent building regulations and demands for higher quality standards with durability, safety and economy.



TRILITE RMS is a modern, practical construction material of outstanding performance which is cost effective. It had been use in numerous high fire risk areas, fire protection applications, manufacture of fire doors.



TRILITE RMS is a fire retardant board with good noise attenuation and acoustic properties. It is fitted directly to metal wall frames as a backing board. It also has the capability to accept direct render.

- Exterior Cladding
- Exterior Wall
- EIFS Systems
- Ductwork
- Access Panels
- Agricultural Bldgs.
- E&M Service Enclosures
- Infill for Sandwich panels
- Passive Fire Protection
- Elevated Floor underlayment
- Interior Impact Wall

- Prefabricated Homes
- Interior Walls
- Linings / Partitions
- Moisture Area Wall
- Decorative backing boards
- Interior Fire Rated Walls
- Furniture backing board
- Replace plywood & MDF
- Underlay of wet areas
- Ceramic Tile Substrate
- Countertops



Water & Moisture Resistance

Technical Specification

Test Properties	Test Standard	Unit	Test Result
Water Vapour Transmission	BS EN ISO 12572	Grams / m ² . Day	48.1
Water Vapour Permeability	BS EN ISO 15148	Kg /m ² . H 0.5	0.142
Freeze Thaw after 100 cycles Modulus of Rapture (MOR)	BS EN 12467	N/mm ²	Parallel : 15.7 Perpendicular : 10.1
Thickness Swelling after water immersion	BS EN 317	%	0.2
Soak Dry after 50 cycles Modulus of Rapture (MOR)	BS EN 12467	N/mm ²	Parallel : 15.8 Perpendicular : 11
Moisture Content	BS EN 322	%	9.4
Bending Strength after 24 hours soak in water	BS EN 12467	N/mm ²	Parallel : 17.2 Perpendicular : 13.4
Cyclic test in humid condition	BS EN 321	N/mm ²	0.97
Dry to soak movement	CNS 13778	%	0.3
Moisture absorption rate	CNS 13778	%	32
Length Expansion rate	CNS 13778	%	0.06

Mechanical & Thermal Resistance

Test Properties	Test Standard	Unit	Test Result
Compressive strength	BS EN 12390-3	N/mm ²	8.3
Bending strength	BS EN 310	N/mm ²	12.1 - 17.1
Modulus of elasticity	BS EN 310	N/mm ²	5210 - 7845
Tensile strength	BS EN 12467	N/mm ²	3.60
Screw Withdrawal strength	BS EN 320	N/mm ²	69 - 87
Thermal conductivity	EN 12664	W/mK	0.21
Impact strength	BS 5669:part 4	MM/MM	23
Racking strength	EN 14358	KN	16.98 (on 5kN)- 12mm 12.09 (on 5kN)- 9mm 8.41 (on 0kN)- 12mm 7.52 (on 0kN)- 9mm
Surface Alkalinity	BS 6829	PH	9.5 - 10

Airborne Sound Resistance

Test Properties	Test Standard	Unit	Test Result
12mm board partition wall	BS EN ISO 717-1	Rw	48db
9mm board partition wall	BS EN ISO 717-1	Rw	45db

Microbiological Resistance

Test Properties	Test Standard	Unit	Test Result
Determination of asbestos content	NIOSH 9002		None detected
Formaldehyde content check	ISO 14184-1		None detected
Fungi & Mold Resistance	ASTM C-1338		No Growth occurred

Dimensions

Density : 1100 kg/m³ (± 12%)
 Thickness : 3mm upto 18mm
 Width : 1220mm , 915mm
 Length : 3000mm, 2440mm, 2700mm, 2135mm

** Special dimensions can be made to order upon request **

Product Tolerances

- Length & Width Tolerance : - 2mm , + 3mm
- Squareness of boards : ≤ 2 mm
- Straightness of edges : ≤ 5 mm
- Thickness Tolerances :
 - 3mm to 4mm = -0.2mm , +0.2mm
 - 6mm to 9mm = -0.3mm , + 0.3mm
 - 10mm to 12mm = -0.8mm , + 0.8mm
 - 15mm to 18mm = -1.0mm , + 1.0mm
- Edge : Square , Tapered, Bevelled, Rebated
- Backside : Sanded or Unsanded

- Non deforming, minimal contraction/expansion
- Noncombustible, Fire-proof
- A1 European Fire Resistant Board
- Upto 180 minutes fire protection
- 100% Water Resistant, moisture resistant
- Energy Saving, great insulating property
- Multipurpose, versatile both interior/exterior
- Mold, termite, fungus, bacteria resistant
- Light weight, high impact resistance
- High Dimensional Stability
- Extra Strength & Durable
- Good Acoustic performance
- Easy Installation, fast and time saving
- Odourless and Non-toxic under fire.



Test Properties	Test Standard	Test Result	Unit
Durability			
<i>TRILITE® RMS board fulfill the requirements of the highest durability category "A" board according to EN 12467:2012 test standard meaning the board can be subjected to heat, high moisture and severe frost.</i>			
Water Impermeability	EN 12467	Category A	No signs of water penetration after 24 hours, No dampness or dripping on the undersides of the board.
Heat Rain Incorporating Thermal Shock from water spray (50 cycles)	EN 12467	Category A	No bowing, warping, cracking, or delamination occurred. No deterioration, no traces of moisture nor water drop formation.
Freeze-Thaw (100 cycles)	EN 12467	Category A , post Freeze-Thaw MOR = 12.9 Mpa	No visual damage noted on completion of the 100 cycles
Soak / Dry (50 cycles)	EN 12467	Category A, post soak/dry MOR = 13.5 Mpa	No visual damage noted on completion of the 50 cycles
Bending Strength after 24 hours soak in water	EN 12467	Category A, MOR = 15.3 Mpa	Classified as a Class 4, Category A board
100% Safe, Non-Toxic and Non-Harmful to Health			
<i>TRILITE® RMS board has been approved as "M1" (highest) product by the Finnish Building Information Foundation RTS, the emission classification body for Building Materials in Finland for European market.</i>			
VOC, TVOC Emission (Volatile Organic Compounds)	EN ISO 16000-9, EN ISO 16000-6	0.004 mg/ (m2 h)	M1 Classified , VTT tested Finland
Formaldehyde Emission	EN 717-1	< 0.005 mg / (m2 h)	
Ammonia Emission	In house method of VTT	< 0.005 mg / (m2 h)	
Carcinogens Emission	EN ISO 16000-9, EN ISO 16000-6	< 0.001 mg / (m2 h)	
Sensory Evaluation	EN ISO 16000-28	PASS	
Fungi Resistance	ASTM C-1338	Fungal Resistant - No growth	Biosan Lab - USA
Alkalinity	BS 6829	Sodium Oxide : 56.7% (ph between 9.5 - 10)	TUV Sud - Singapore
Sulphide S ² content	BS EN 196-2	No Sulphide S² Content	
Evaluation of Toxic Fumes generated during burning	BS 6853	100% Non-toxic below the IDLH value of listed gases, summation index R, is less than 0.3	

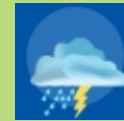

Category A Building Board to EN 12467 suitable for applications subjected to heat, high moisture and severe frost.

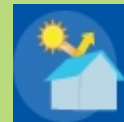

Thermal Insulation Properties high level of resistance to thermal movements .



Water Impermeable, Moisture Resistant will not physically deteriorate when immerse in water , a strong moisture barrier board.

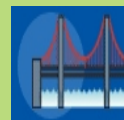

Dimensionally Stable Strong, irreversible chemical properties , minimum thermal movements and non shrink with changes in temperatures .

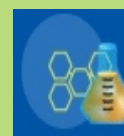

High Quality Raw Materials We are the pioneer and the first manufacturer to develop the magnesium based boards with a unique , un-match composition to date.

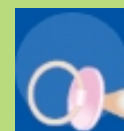

Low Carbon Manufacture Produced from natural cure process with very low energy consumption and drying stage unlike other autoclaved products.

TRILITE RMS is the leading exterior based board for applying direct render coating in Europe. Meeting the ever increasing, higher standards of durability, economy and safety.

AS AN EXTERIOR RENDER BASE BOARD



Tested with a very successful outcome to the following :

- *Hydrothermal Freeze Thaw Conditions*
- *Soft & Hard Body Impact*
- *Bond Strength*
- *Wind Loading*

Fixing and Jointing

Board Framing

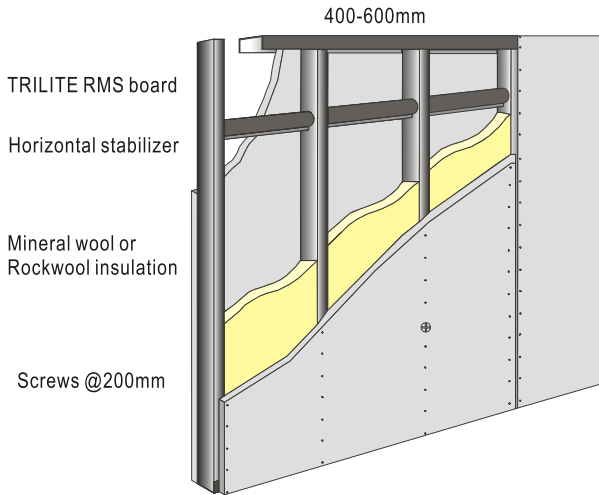

- Before installing, ensure the frame and floor area is level and clean from dust and other debris.
- Framing structure spacing should be supported vertically, thinner boards should be fix @ 400mm centre by studs. For thicker boards at not more than 600mm centre by studs.
- Centres can be adjusted to avoid clashes with frame fixings underneath. All edges should coincide with support structure.
- Screws must be driven flush to the board, not countersunk or exposed
- Boards must be screwed not less than 15mm from the edges of the framing.
- When fixing, start at the centre and work outwards to prevent distortion within the boards. Boards should be offset so that 4 corners never meet at one point. A 6-8mm gap should be left between the ceiling & floor level for movements.

Board Arrangement

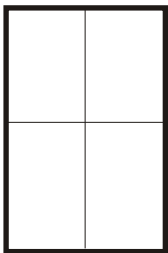

Do not use 4 way joints

- When fixing the boards to frames, use a "brick bond" arrangement as shown below.
- Minimum board width should not be less than 70mm.

Horizontal board arrangement

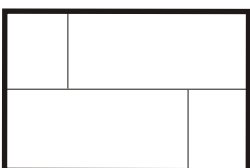

Vertical board arrangement

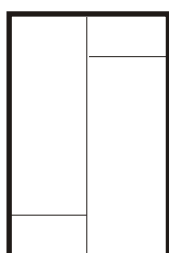

Curving Application

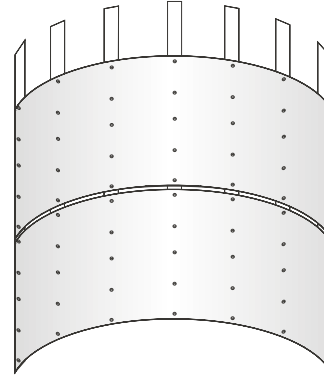

TRILITE RMS in 3mm and 4mm thickness are suitable for use into various curvatures to match designer's imaginations with a fire and water resistant board.

Applications : curved ceilings, walls, columns, eaves soffits, areas with high fire risk requirements like hotels, shopping malls, schools, hospitals, offices, railways concert halls among others.

Thickness	Minimum Bending Radius
3mm	500mm
4mm	600mm

Note : Fix board on its horizontal positions.
For thicker board requirements, you can layer the various thickness to achieve desired total thickness.

Board Jointing

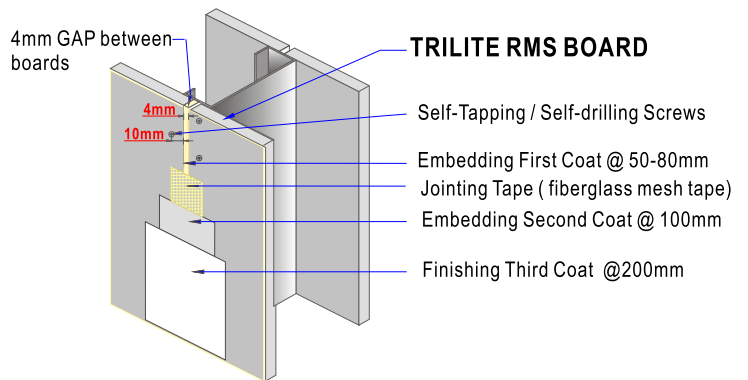

Step -1 First Coat

Apply an elastic/flexible joint compounds at joints. Silicon for the corners & edges. Fill the gap with the compound using a clean putty knife about 5-8cm wide along the joint evenly. Wait to dry and when it is almost dry firmly embed the self adhesive fibreglass tape centrally into the joint.

Apply jointing compound on the tape with the tapping knife and use sufficient pressure to ensure the tape is firmly placed and free from trapped air/bubbles.

Wait to dry and remove extra material lying outside of the joint and sand away any excess elastic joint compound.

Step -2 Second Coat

When the first coat had dried, apply the second coat of jointing compound with a wide clean putty knife about 10cm and let it dry completely. Remove extra material lying outside of the joint and allow it to dry.

Step -3 Second Coat

When the second coat has dried, apply a very thin layer of jointing compound at 20cm to touch up any uneven surface, remove extra material and allow it to dry. Ensure that the preceding application and tape is completely covered and spread it to remove visibility of the joint.



Handling and Storage

Storage of boards

Store flat on a flat pallet or rack above ground level with evenly distributed dry timber support. Cover with plastic sheeting to protect from rain or moisture. Keep dry and store in a dry and covered area. Support timbers at maximum of 400mm centre. Never stack boards on its edges or upright positions.



Transport of boards

Transport boards stacked on the original pallet by forklift or crane. When loose boards are transported they must be laid flat and fully protected with waterproof or plastic sheets. When manually moving, the boards must always be carried in a vertical position.

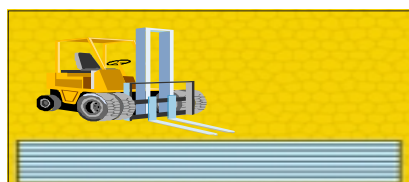

Handling of boards

Boards should be lifted sideways and carried on its long edges. Single boards to be handled vertically, avoid dropping the board on the corner.



Conditioning of boards

TRILITE RMS has an ex-work moisture content of 9% (+/- 3%) and is in equilibrium when the temperature is 20 C with a relative air humidity of 50 - 60%. It adapts to the ambient humidity level, therefore to adjust to its working conditions it should be allowed to acclimatise for 24 - 48 hours prior to fixing.

Installation Guide

Expansion Gaps

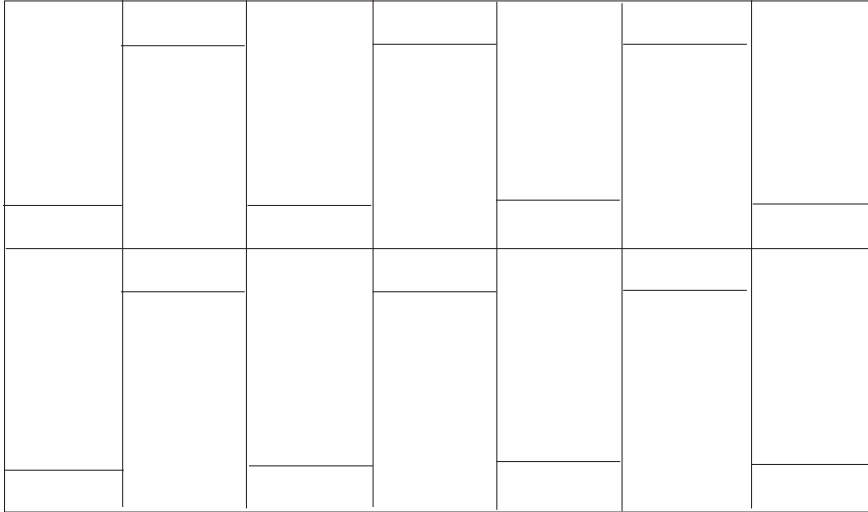

Within a single frame assembly up to 9000 x 4500mm maximum, expansion gaps between boards should be 4mm.

Where 2 frame assemblies meet, expansion gaps to be 10-12 mm.

Support structures should be at a 400mm, maximum of 600mm centres, there should be a 4mm gap between each boards and on all edges. Boards joints should be treated accordingly with a flexible joint compound.

Conditions for fixing frames over the above size must be covered on a project basis and local building regulations must be applied.

Screwing



- Screw fixing should be self drilling /self countersinking screws in galvanized steel or stainless steel.
- Screw diameter should be from 3.5 to 4.2mm and length should be 2.5 to 3 times the thickness of the board.
- Screw heads should be just below the surface of the board and not driven too deep.
- Screw heads are to be covered with the jointing compound to achieve the right finished surface.

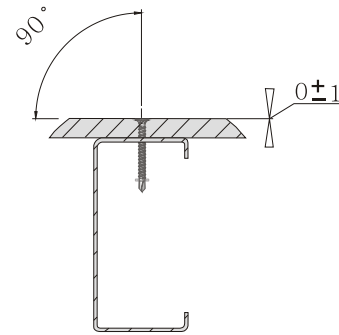

Note:

- 1.1 When fitted, the head should be flush with the surface of the board +/- 1mm.
- 1.2 The screw should also be fitted normal to the board +/- 5 degrees.

Before



After



Fixing Centres

Diagram 1 : Fixing Centres and Fixings

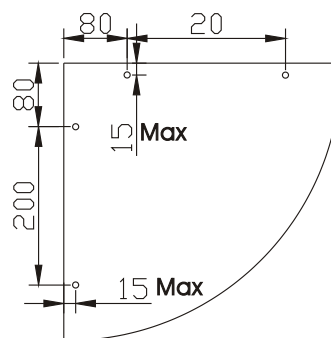
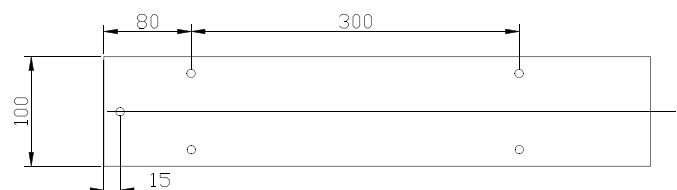

Diagram 2 : Minimum Board Width



Cutting

Machining

TRILITE RMS is machined and processed using tungsten carbide tipped blades at all times.

Type of Blade

Alternative or trapezoidal teeth.

Chart shows the number of revolutions and number of teeth (Z).

Diameter (mm)	250	300	350	400
Board thickness up to 12mm	Z = 48	Z = 60	Z = 72	Z = 72
Board thickness exceeding 12mm	Z = 36	Z = 48	Z = 54	Z = 60
Number of revolutions rpm	3000 / 4500	3000	3000	3000 / 1500

Milling: Common machines with carbide tipped tools. The higher the rpm, the better the milled edge.

SAWING

- Portable circular saw
- Cross cut hand saws for thickness up to 12mm
- Jigsaw for thickness up to 12mm and small work
- Fixed saw for dimensioning (vertical or horizontal)

Drilling

For making holes on the board, use a masonry drill, use low-high speed drills for better results. Place the board under the drilling location for a clean hole, do not use hammer action.

Surface Laminating

TRILITE RMS is suitable for bonding to all decorative substrate. For bonding adhesive, you could consult with the local adhesive manufacturer and pre-testing is advisable. Make sure that no dirt or air comes in between the adhesive and board otherwise bubbles may occur and bonding is not tight. Ceramic tiles can be applied to the board surface by using branded tile adhesive.

Painting

Ensure that all surfaces are clean, dry and free from dust, dirt or sanding residue before applying paint. Using brand paints usually give good results and always follow the paint manufacturer recommendation.

For external applications apply sealer or primer (refer to paint manufacturers specification) and remove the surface of any dust, dirt, grease or substances that may affect the bonding of the paint.



Before



After

Noncombustible Suspended Ceiling System



Fire Rated Suspended False Ceilings Assessed Performance to BS 476 Part 22

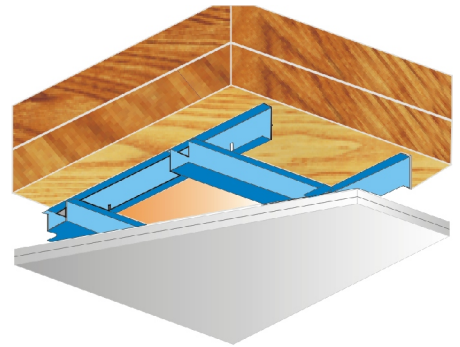

Ceiling channel height = 25mm
fixed at 400mm centres.

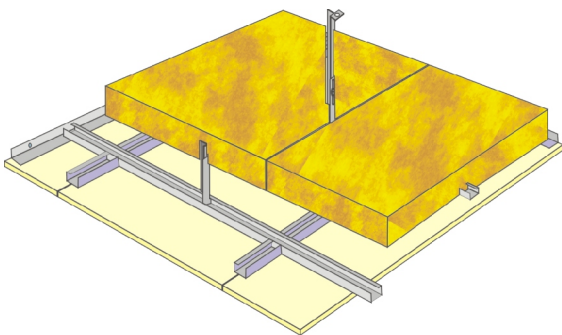

1. TRILITE RMS BOARD
2. Ceiling Channel Section 50 x 27 x 0.6mm at 610 x 1220mm spacing.
3. Wall angle 19 x 32 x 0.5mm
4. Mineral wool insulation
5. Self tapping M4 Screws at 300mm centres.
6. M6 Screws at approx. 350mm centres.

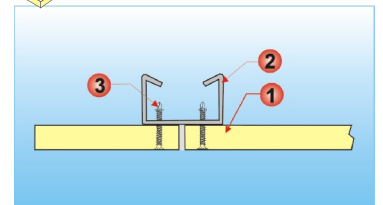
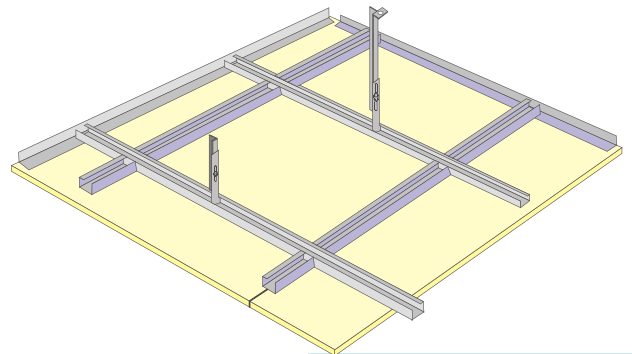

1. TRILITE RMS BOARD
2. U Channel 50 x 27 x 0.6mm at 610 x 1220mm spacing
3. Galvanized Self-tapping screws

Acoustic and Noncombustible Flooring System

TRILITE RMS boards are flooring substrate may be fixed to timber or steel joists. The type, size and final spacings of the joists should be determine by the structural engineers. The thickness of the joists or width must be sufficient (45mm minimum) to allow correct fixing. The boards are fixed so the lengthwise direction is spanning across the joists. Where load requirements are greater, all board edges must be supported as in Fig. C. It is recommended to apply a layer of adhesive between the board edges.

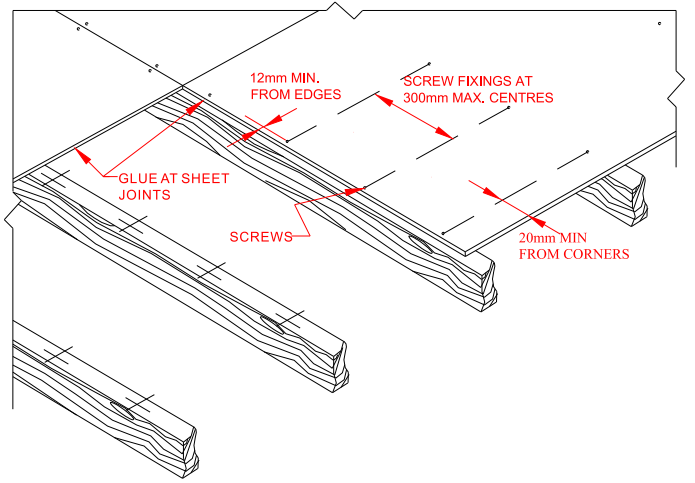

FIG.B - FIXING FOR RESIDENTIAL APPLICATIONS AND TOILET OR SHOWER AREAS

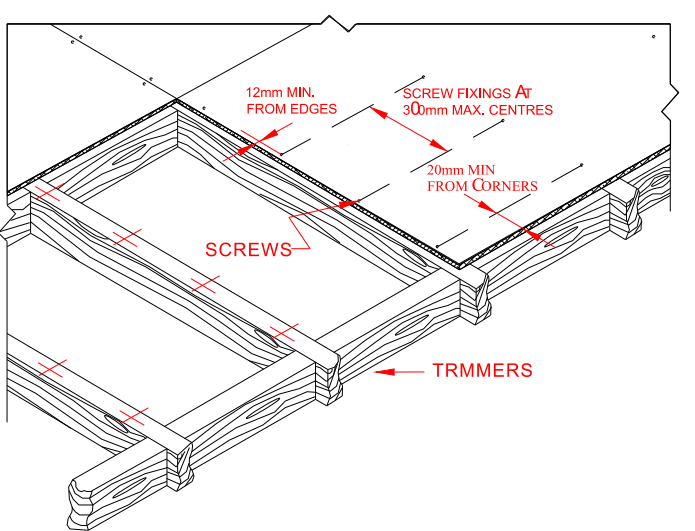

FIG. C - FIXING FOR GENERAL COMMERCIAL APPLICATIONS

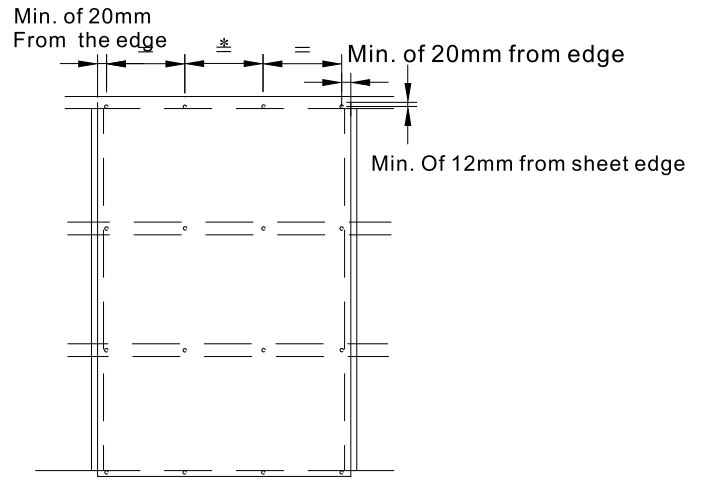

FIG. A1 - SPACINGS OF FIXINGS -1220mm WIDE SHEET PLACED ACROSS JOISTS

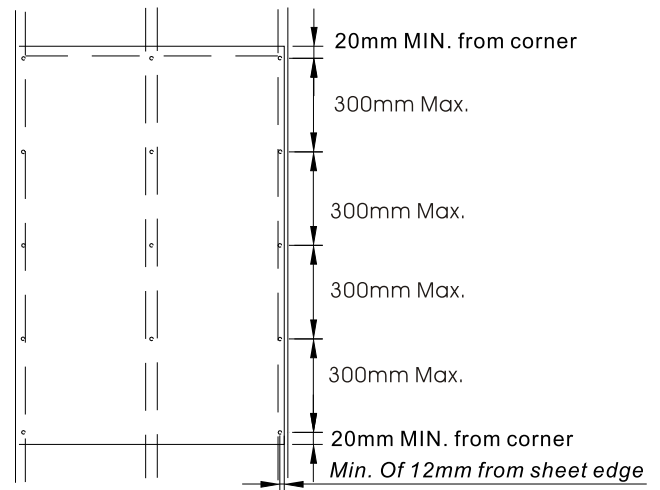

FIG. A2 - SPACING OF FIXINGS -SHEET PLACED ALONG JOISTS

- Use screws with countersunk heads and screws at 300mm centres ensuring screw heads are flush with the surface. Make sure that the surface is clean and even before laying the boards.
- Stagger all board joints ensuring they don't align with sub-floor joints. Four corners of the boards must never allow to meet at one point. Apply an even layer of tile adhesive with a trowel to the sub-floor before setting the board firmly and evenly in place.

Tile Backer Board in Wet Areas



Interior Partition Walls



Eaves Lining Installation

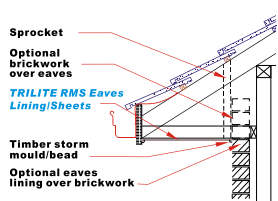

Fig. 1 Boxed Eaves - Brick Veneer Wall

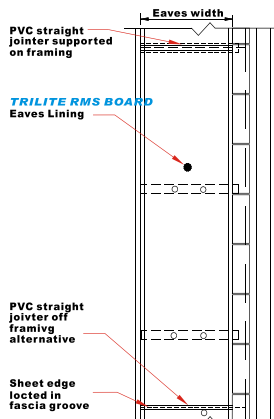

Fig. 2 Boxed Eaves - Plan

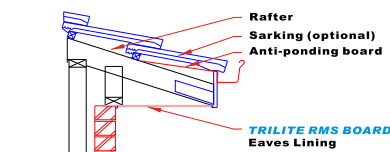

Fig. 3 Simple Spanning Eaves - Brick Veneer Wall

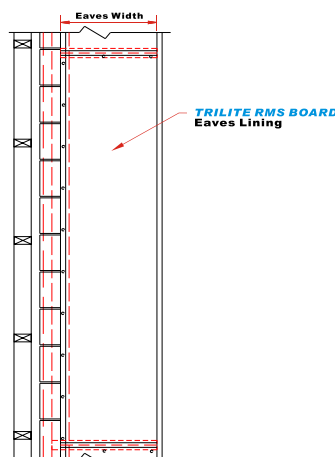
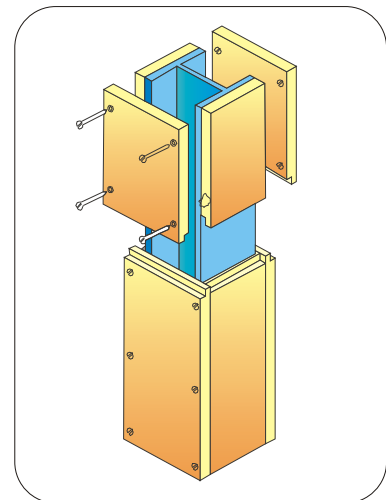

Fig. 4 Simple Spanning Eaves - Plan

Ducts and Steelwork Protection

TRILITE RMS boards can be applied for fire protection of structural steelworks, Fixed by edge screwing or stapling boards together. Fast and economical to install.





Stable Quality
Reliable Partner
Durable Products

Your perfect Choice for your projects



Website : www.triliteboard.com



Manufacturer :
Triple Lite Incorporated

**2F, 78 Fenliao Rd. Section 1 Linkou District,
New Taipei City, Taiwan R.O.C**

Tel : (886-2) 86013869 , 86013870

Fax : (886-2) 26018859

Email : triple.lite@msa.hinet.net

CE
Marked

Distributor / Agent